



XC7-SR04

SKID STEER LOADER



SOLID TO SUCCEED



Operating Weight 1550kg

Bucket Capacity 0.17m³

Rated Power 18.4kW

Add:No. 99 Kunpeng North Road, Economic and Technological
Development Zone, Xuzhou City, Jiangsu Prvince
Zip code:221122

Version:N202505V1



XCMG OFFICIAL WEBSITE



MAIN SPECIFICATION

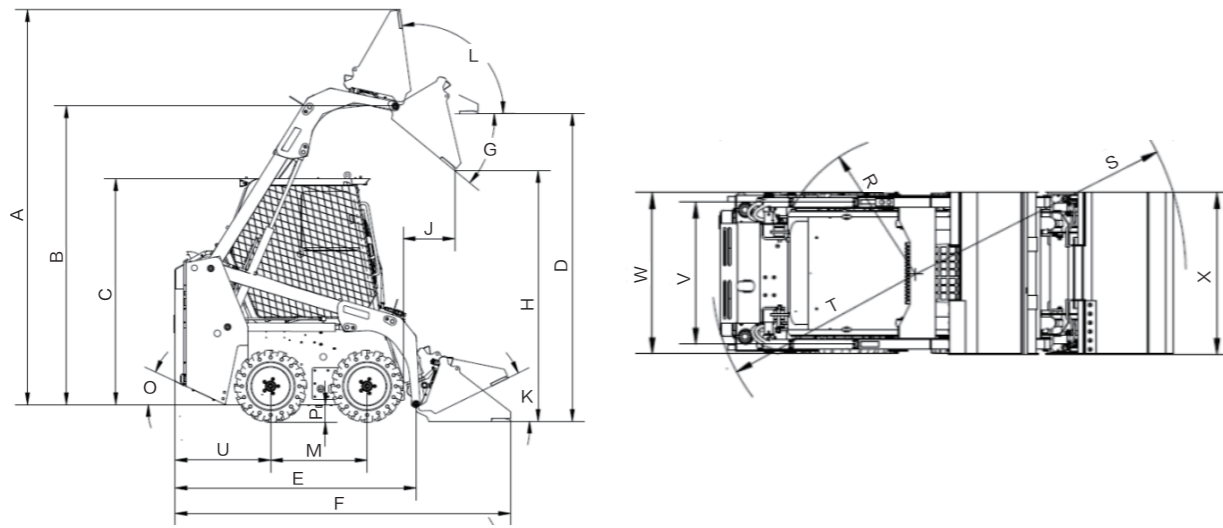

Dimension and Specification	Parameter
A	Max.operation height 3139 mm
B	Height to the hinge pin 2407 mm
C	Height to top of cab 1854 mm
D	Clearance:level bucket 2275 mm
E	Overall length(without bucket) 1793 mm
F	Overall length 2545 mm
G	Dumping angle 34 °
H	Max.dumping height 1887 mm
K	Rollback angle:on the ground 22 °
L	Rack angle at full lift 97.5 °
J	Dumping reach 462 mm
M	Wheelbase 735 mm
O	Departure angle 22 °
P	Ground clearance 135 mm
R	Front turning radius (without bucket) 780mm
S	Front turning radius (with bucket) 1500mm
T	Rear turning radius 1140mm
U	Length: rear 726 mm
V	Wheel track 755 mm
W	Width over tyres 896 mm
X	Width over bucket 1110 mm

Category	Item	Parameter
Overall Parameter	Rated Load	385 kg
	Tipping Load	770 kg
	Operating Weight	1550 kg
	Max. Breakout Force	9.2 kN
	Max. Traction Force	12.6 kN
Engine	Rated Power	18.4 kW
	Emission Stage	EU Stage V Emission Standard
	Rated Speed	2800rpm
	Cooling Pattern	Hydrocooling
	Cylinder Amount	3
	Bore	77 mm
	Stroke	81 mm
	Displacement	1.131 L
	Max. Torque	67.5 N · m@1600~2000 rpm
Performance Parameter	Operation Mode	Mechanical control & multifunctional electric control
	Tyre	5.7-12 (solid tyre)
	Max. Speed	10 km/h
Hydraulic System	Hydraulic Flow	37.8 L/min
	Hydraulic Pressure	190 bar
	Total Circle Time	≤7.8 s
Other	Bucket Capacity	0.17 m ³
	Disel Tank Capacity	30 L
	Hydraulic Oil Tank Capacity	26 L

- The technology of XCMG wheel loaders is subject to constant improvement and upgrading. In case the specifications or detailed appearance contained in this brochure differ from actual products, the latter shall prevail.
- XCMG reserves the right of final interpretation for the above. Our products may be modified without prior notice to users.